

# **RICHTER HANSEN**



## **Marine Equipment**

### **”Pilot Ladder”**

**For pilot access to ship under on-board conditions**

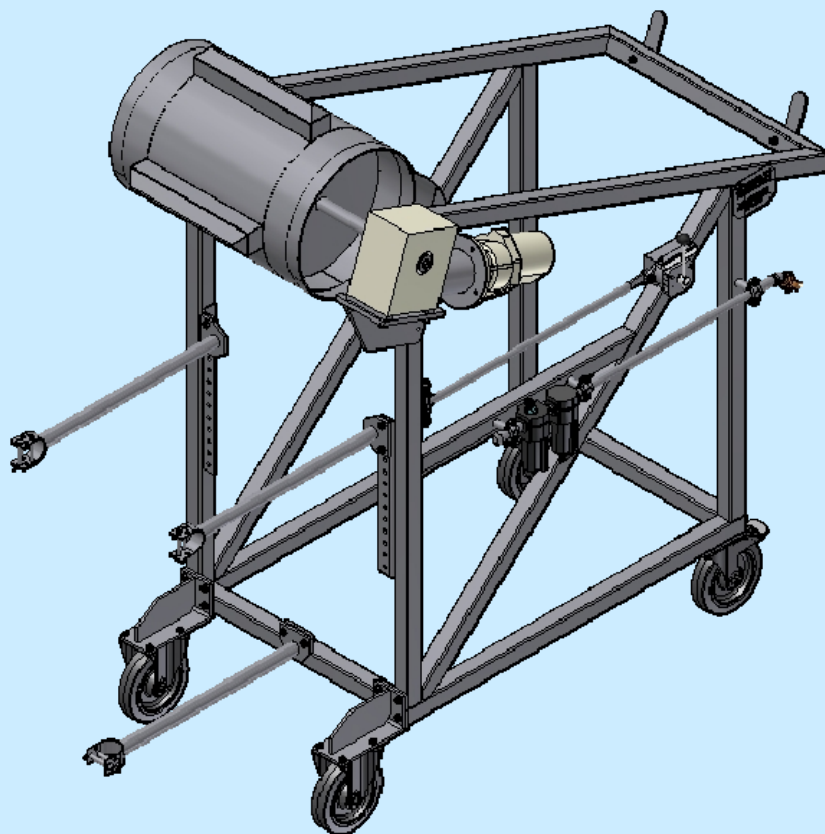

**For on-board access the Richter Hansen Pilot Ladder is a excellent choice -  
Easy to use and easy to handle**

# RICHTER HANSEN



## User guide for Pilot Ladder

### Installation Recommendations:

- It is the user's responsibility to determine a safe sequential installation procedure.
- Ensure the Pilot Ladder is securely fastened to any temporary lifting equipment that may be used during installation.
- Confirm that the anchor pins are securely fastened and the stiffening bar installed correctly before the platform is put into use.
- Provide secure dependable access to the Pilot Ladder. Access may not contribute loading to Pilot Ladder or otherwise impede Pilot Ladders functionality.

### Safety Recommendations:

- Pilot Ladder may not be occupied while fastened to any temporary lifting equipment that may be used during installation.
- Under ***NO*** circumstance may shields and/or railing be removed or altered.
- Use of the Pilot Ladder shall stop immediately if installation of the Pilot Ladder is determined to be faulty or insufficient.
- Safety helmets shall always be worn during installation and use.
- Special attention should be paid to small loose parts on the Pilot Ladder that present a risk of stumbling/tripping and a potentially fatal fall.
- It is recommended to use safety belt or similar equipment while operating on the Pilot Ladder.
- No more than one (1) person at a time on-board the Pilot Ladder
- The maximum load on the platform may not exceed more **125 kg (250 lbs)**